

Nos. 21A, 23A, 25A & 27A

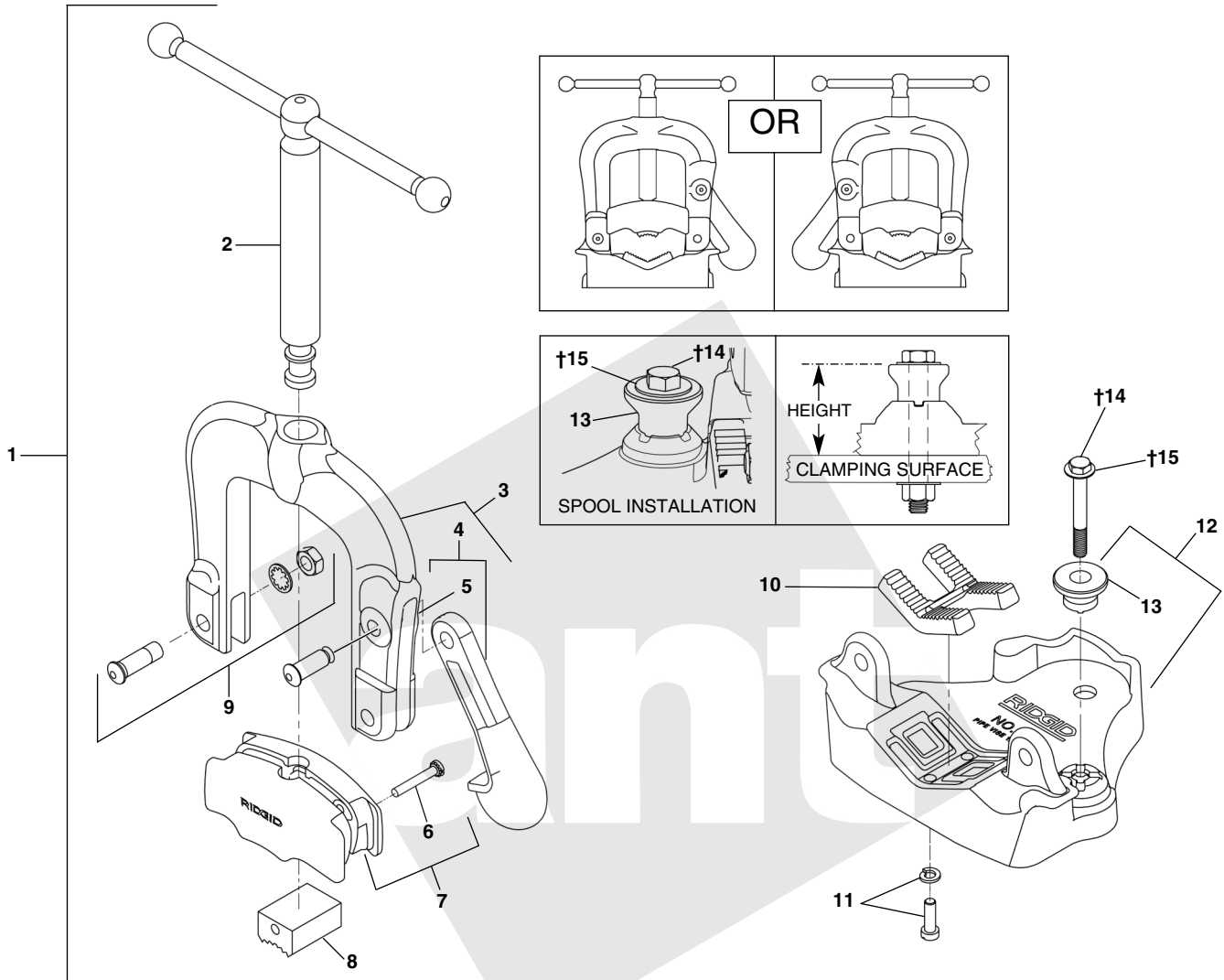

**NOTE: Order parts by Catalog Number only.
DO NOT order by Reference Number.**

Ref. No.	Description	21A ½" - 2"	23A ¾" - 3"	25A 1" - 4"	27A 1½" - 6"
1	Yoke Assembly	40315	40430	40520	40625
2	Feed Screw	40355	40440	40535	40645
3	Yoke & Hook Assembly	40310	40425	40515	40620
4	Hook Assembly	40320	40435	40525	40630
5	Hinge Pin	40340	40470	40555	40670
6	Jaw Clamp Screw with Washer (2)	40345	40385	40530	40635
7	Jaw Clamp Assembly	40360	40445	40540	40650
8	Upper Jaw	51783	40455	40545	40590
9	Hinge Bolt, Washer and Nut	40325	40465	40560	40665
10	Lower Jaw	44858	44858	41020	41085
11	Jaw Screw with Washer (2)	48288	48288	50188	50193
12	Base Assembly	50168	50173	50178	50183
13	Spool	48298	48383	48383	48388
†14	Recommended Bolt Size	¾"	1"	1½"	2"
†15	Recommended Washer Size	¾"	1"	1½"	2"
*Height	Spool and Base Height (inch)	2"	2½"	2¾"	3"

† Ref. No. 14 & 15 not provided
Minimum Grade 5 Bolt